

S P 1 2 3 0 - 6
PTP MACHINERY CENTER

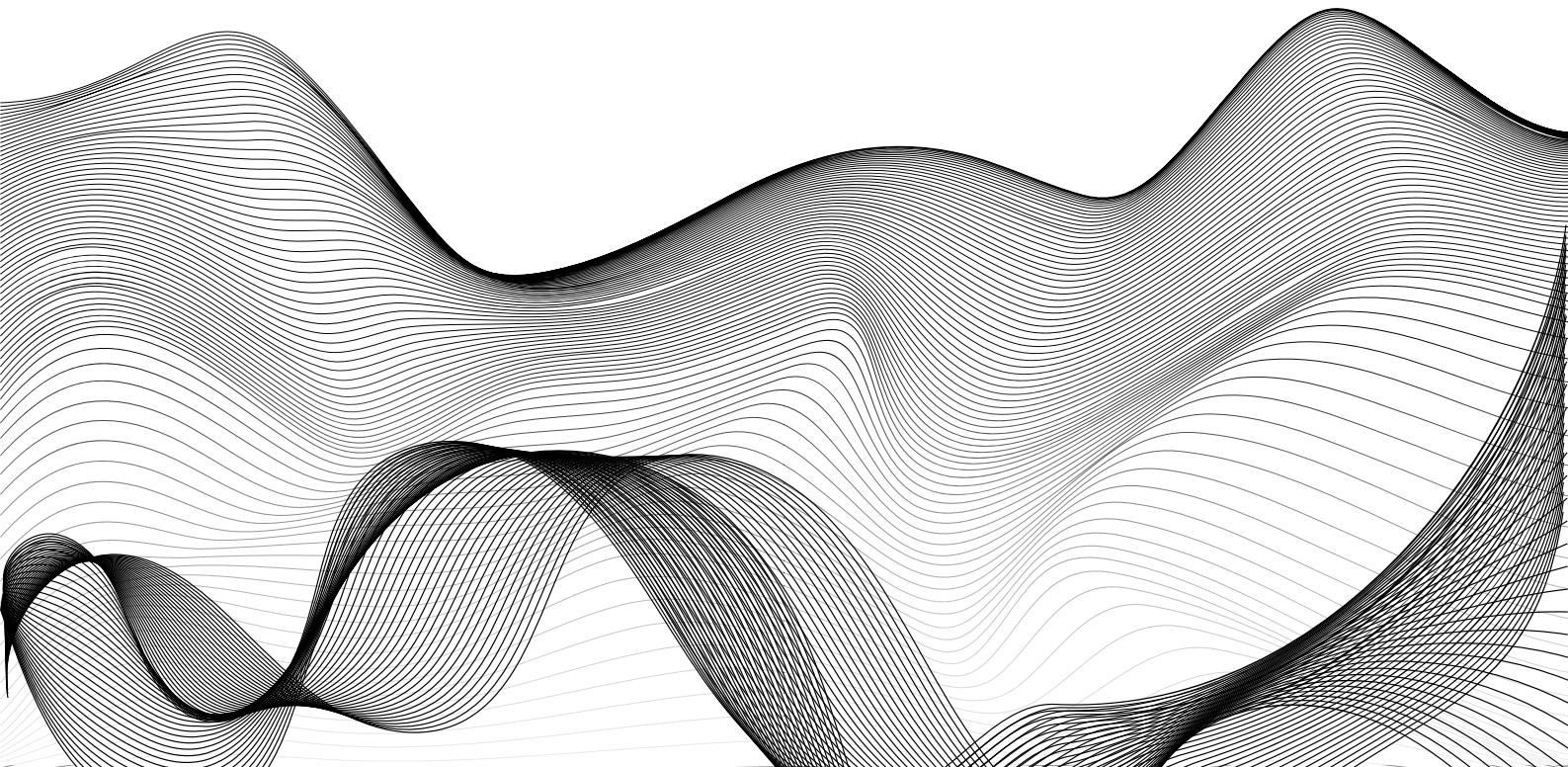



We Simplify and Optimize
your Manufacturing



WOTSO SP1230-6

PTP WOODWORKING CENTER

Features:

- **Versatile Functionality:** Designed to handle complex processing tasks, including routing, drilling, cutting, side milling, sawing, and slotting.
- **Four Work Zones:** Allows for flexible fixture arrangements during product processing.
- **Seamless Integration with CNC Woodworking Center:** Enables automatic scan code processing, significantly improving production efficiency.
- **Hat-Type Automatic Tool Change System:** Equipped with an 12-slot carousel tool changer for stable and efficient operation.
- **High-Precision Grinding Rack from Italy:** Combined with Taiwan HIWIN 30 guide rail to enhance product accuracy.
- **FEA Finite Element Analysis and High-Temperature Tempering:** Ensures body stability and prevents deformation.
- **Vacuum Absorption:** Capable of whole-plate or point-to-point adsorption, streamlining online processing without the need for sawing. Facilitates loading and unloading, saving time while maximizing output.

WOTSO Group
Carretera de Vigo,74
32001 Ourense - Espanha

www.wotso.eu
geral@wotso.eu

MODEL	SP1230-6
Max working area	3060*1260*100mm
Table size	3060*1200mm
Transmission	XY axis rack and pinion;Z- axis screw drive
Table structure	Moveable gantry;sunction cups
Spindle power	9kw italy (HITECO brand)
Spindle speed	24000r/min
Max traveling speed	80m/min
Max working speed	20m/min
X,Y,Z guide rail	Square rail HIWIN (Y25#,X25#,Z25#)
Tool magazine	Hat type/Carousel 12slots with servo motor (HSK63F)
Drilling head	9vertical+6 horizontal+1 sawing unit(PROTEAN)
Driving system	Yaskawa servo motor
Voltage	380V/50HZ/3PH
Control system	Syntec
Electric cabinet	With air conditioner
Safety Measures	Light barriers
Electrical components	Schneider electric part
Cable	BOSHI flexible towline cable (with shield)

Size description:

Model	Traveling size	Working size	Table size
SP1252-6	5550*1640*250mm	5200*1260*100mm	5200*1200mm
SP1230-6	3400*1640*250mm	3060*1260*100mm	3060*1200mm

Optionals available:

Upgrade 12KW Spindle HSK

Add C axis + Aggregates

Upgrade Tool Magazine to 16 slots

Upgrade Drill Unit 12V+ 6H + 1 SAW

Upgrade Vacuum Pump 2 sets 5.5KW

Syntec System



HIWIN high precision track and pinion



Yaskawa drive motor



Italy HITECO spindle



ZHUOLAN reducer

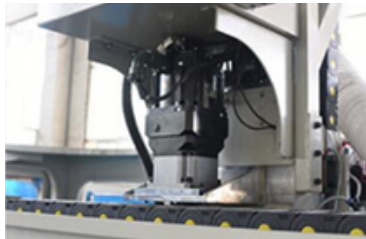

Taiwan protean Drilling group



Tool magazine with 12 tools



Italy adsorbing block

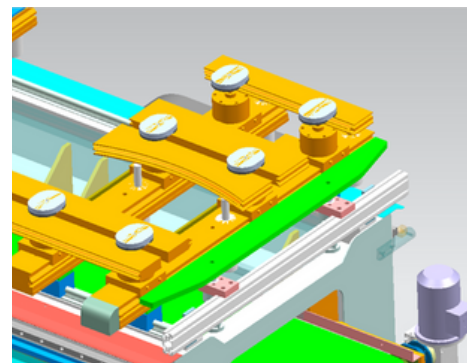
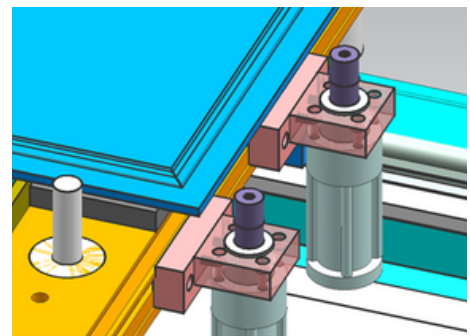
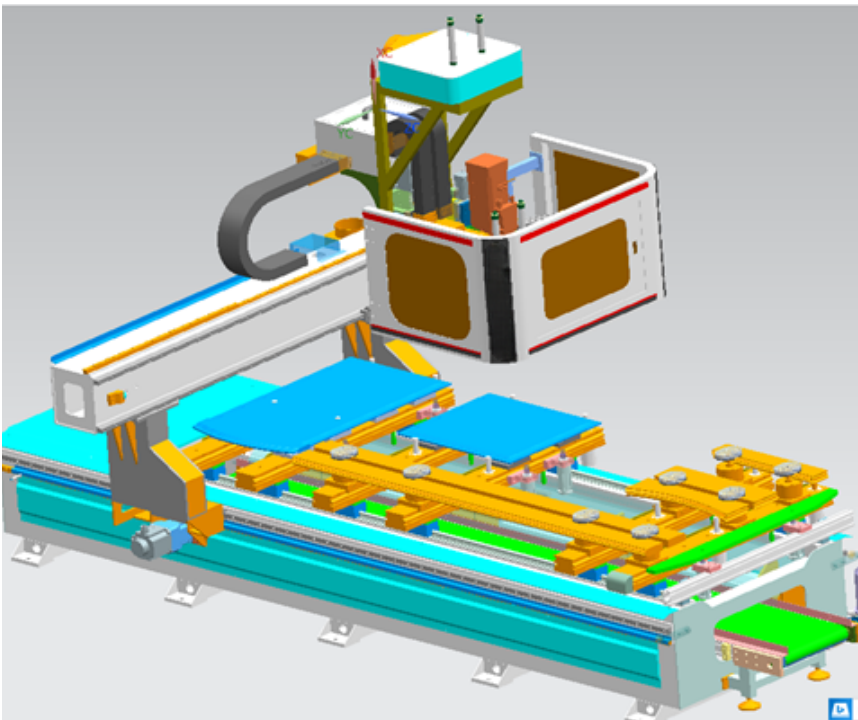

We Simplify and Optimize Your Manufacturing

We Strive to Make Your Production **Smarter**,
Faster and More **Cost-efficient** with minimum human labor required.